

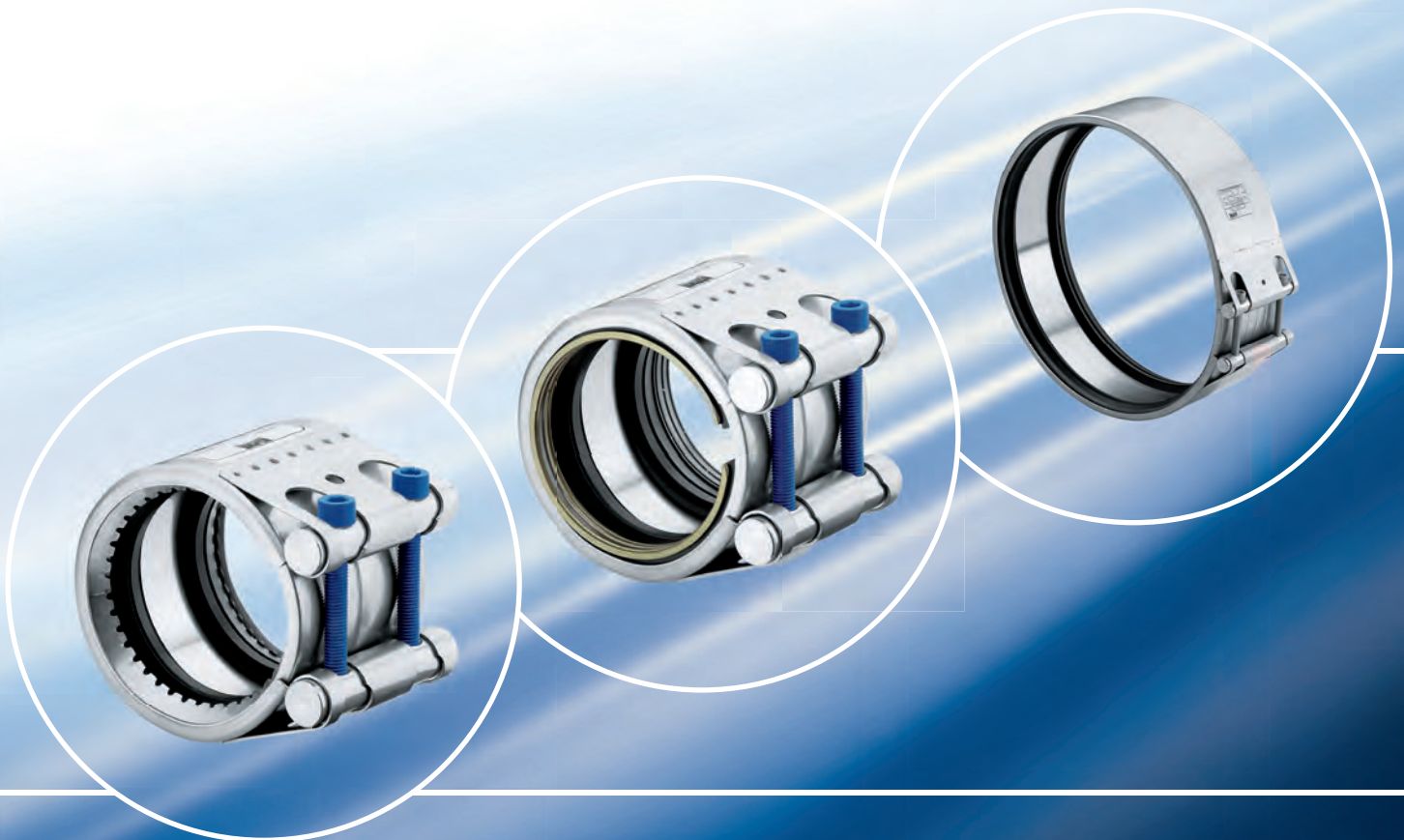







NORMACONNECT® FGR

Pipe Connections



Perfect connections for pipes
in various applications and materials

NORMA® – Contents

	Page
Preface	3
Approvals	4
Product benefits	5–6
Type series	7
Couplings types	8
Materials	9–10
NORMACONNECT® FGR – for axial non-restraint connections:	
 NORMACONNECT® FLEX/FLEX E	11–14
 NORMACONNECT® FLEX 3	15–16
 NORMACONNECT® REP E	17–20
NORMACONNECT® FGR – for axial restraint connections:	
 NORMACONNECT® GRIP/GRIP E	21–23
 NORMACONNECT® RFP	25
 NORMACONNECT® GRIP E-FP	25
 NORMACONNECT® PLAST GRIP/PLAST GRIP E	27–28
 NORMACONNECT® COMBI GRIP/COMBI GRIP E	29–30
Accessories	31
Branches and distribution partners	32–35

Subject to technical modifications. Prices on request.
All orders are subject to our terms and conditions of sale.

As a quality certified company we guarantee constantly high quality standards. NORMA® products are manufactured using modern production techniques and high value materials. They are safe if used for the purpose specified by us and if our fitting instructions are obeyed. If you have any doubts about possible uses and the correct fitting please contact us for advice.

NORMACONNECT® FGR Pipe Connections

Perfect connections for pipes in various applications and materials.

NORMACONNECT® FGR pipe couplings are a compact, economical and reliable means for connecting plain-ended pipes. They are suitable to join plastic and metal pipes and especially pipes made from stainless steel. They can be used in mechanical engineering and construction, shipbuilding, civil engineering and in hydro technology.

Supply pipes as well as exhaust pipes for solid, liquid or gaseous media can be joined easily and safely in a very short period of time even in narrow spaces.

Thanks to the wide range of various types and sizes they are suitable for use both in standard and specialized applications.

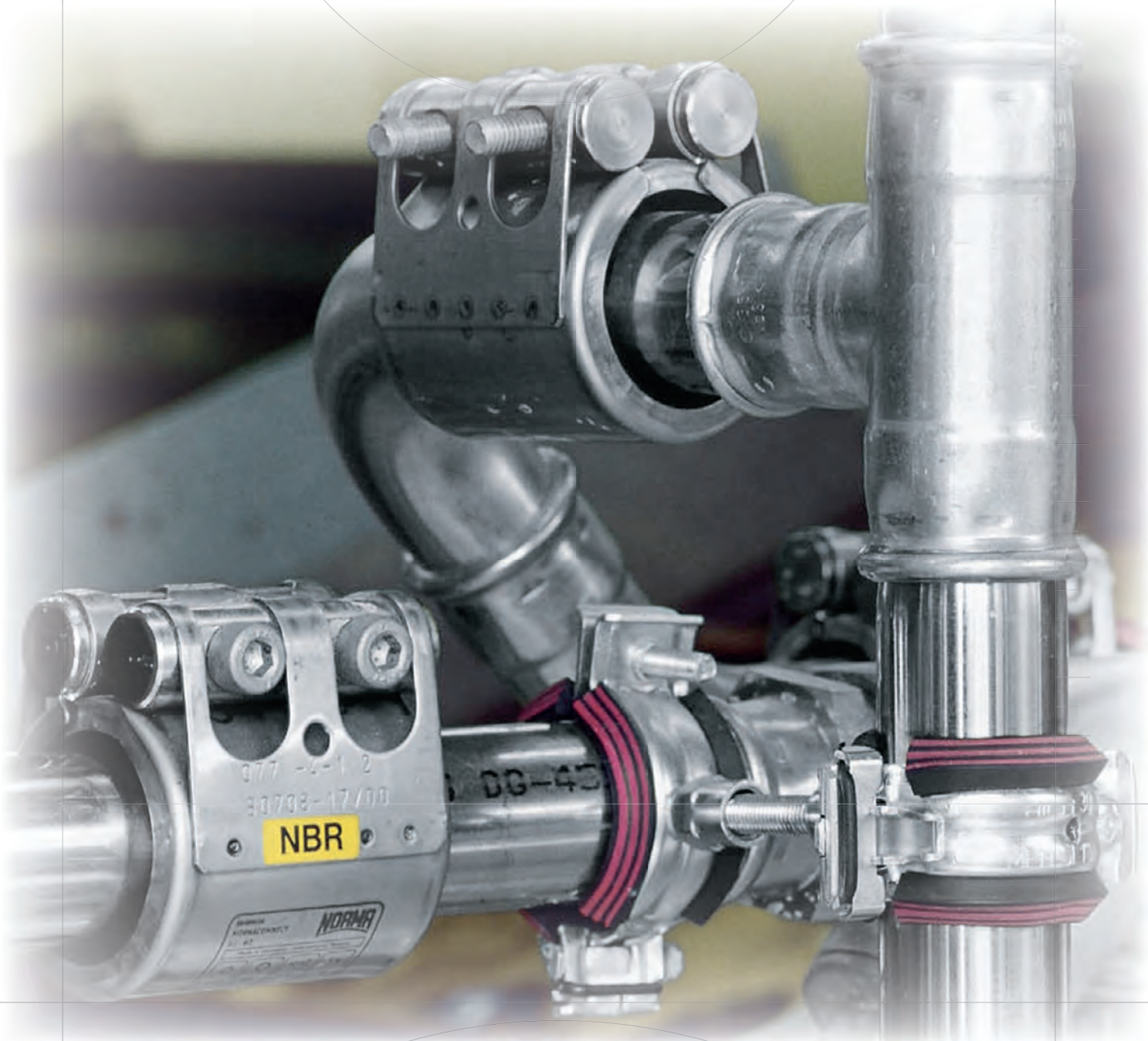

NORMA® – Approvals



Certified and/or approved in compliance
with:
TS 16949
DIN EN ISO 9001
EAQF • FORD Q1
DIN EN ISO 14001

Approvals

NORMACONNECT® FGR Product benefits

NORMACONNECT® pipe couplings are an economical alternative to conventional pipe joining techniques for both plastic and metal pipes. All plain-ended pipes can be joined easily by hand. The ready to fit coupling is pushed over the pipe ends and then aligned and rotated to any fitting position. Tightening the two bolts alternately with a torque wrench is all it takes to make a safe fitting.

- Sealing reliability is also ensured under the condition of slight axial misalignment, angular deflection and even gaps between pipe ends of up to 35 mm (cf. table).
- Pressure surges, vibration and related noise are absorbed to a considerable extent.
- Economy is guaranteed due to short assembly times without the necessity of prior pipe alignment or treatment of pipe ends; in addition, the pipe couplings are reusable.

Range of applications

The NORMACONNECT® pipe coupling is a reliable connection for thick- and thin-walled pipes which conforms to the latest DIN Standard 86128.

Feed and return lines for liquids, gas and solids (for mechanical engineering and construction, civil engineering, shipbuilding, pipeline construction, power stations, mining, filters, water technology, etc.) are joined quickly, easily and safely using NORMACONNECT® pipe couplings.

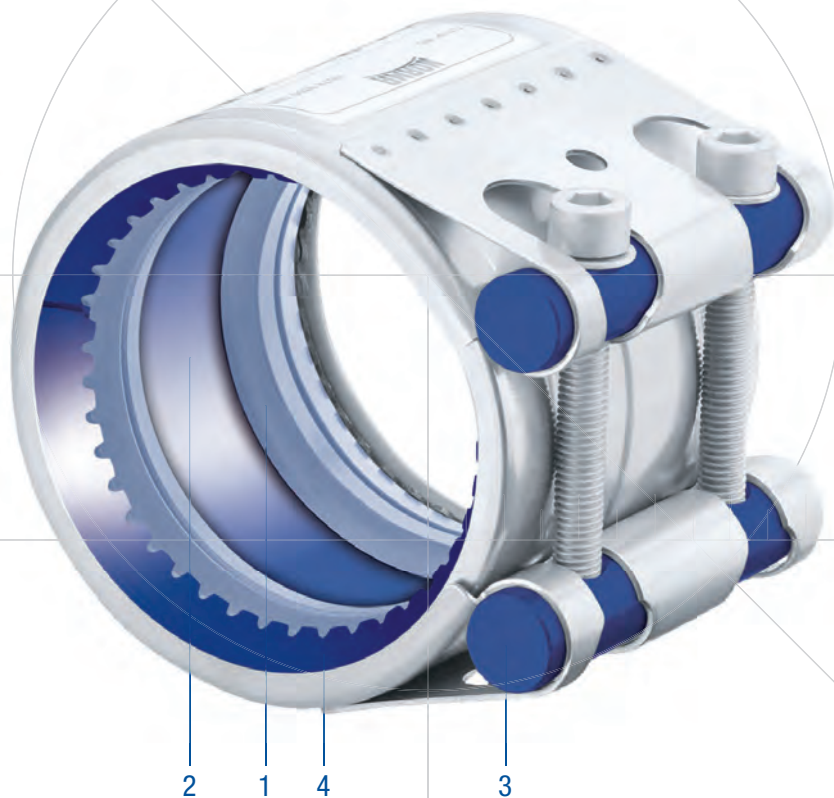

1. Double-lip sealing system

The patented double-lip sealing system (Fig. A) of the NORMACONNECT® pipe couplings offers double safety; It provides maximum sealability at both low and high operating pressures.

When the bolts of the coupling are tightened sealing lip 1 is pressed onto sealing lip 2, thus providing a highly reliable seal even under the condition of low pressures, vacuum or extreme loads acting on the joint (Fig. B).

The special sealing lip design means that when the internal pressure (P) increases, the sealing lips are pressed more firmly onto the pipe surface ensuring an even stronger seal (Fig. C).

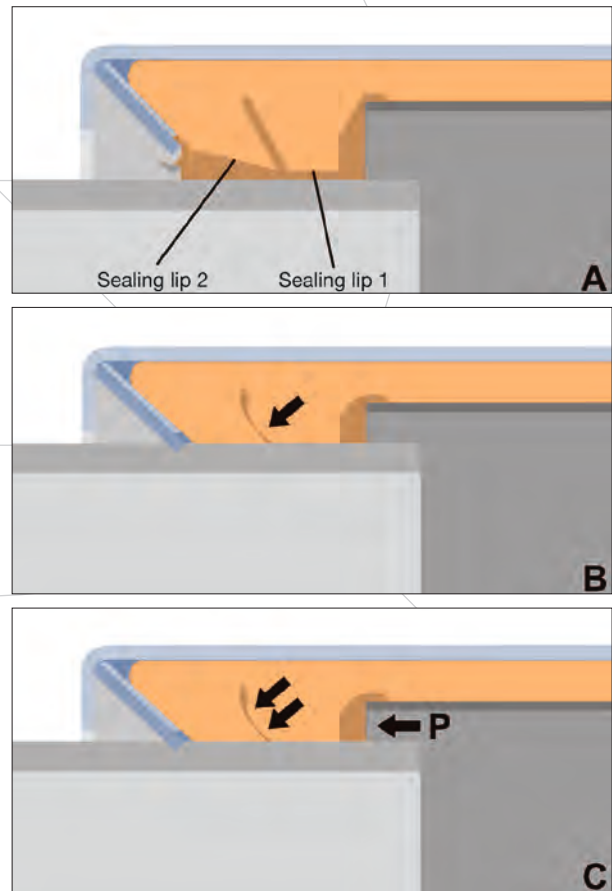

2. Standard strip insert

All NORMACONNECT® pipe couplings are factory equipped with the standard strip insert (2).

The strip insert protects the sealing sleeve from increased mechanical and chemical loads.

It also prevents the sealing sleeve from moisture expansion and allows larger gaps between the pipe ends to be connected. Furthermore, it allows larger angular deflections and misalignment.

With the strip insert the couplings can also be used for both vacuum and high pressure applications without any problems.

The strip inserts are made from plastic material or stainless steel.

3. Heavy duty lock bars

For NORMACONNECT® pipe couplings we use lock bars (3) with a larger diameter. Thus the rigidity of the coupling is increased and the engagement of the threaded end of the locking bolts is considerably improved.

4. Anchoring ring with conically stamped teeth

The anchoring ring (4) with conically stamped teeth indents into the pipe surface and provides safe and strong axial restraint. Owing to the special design the coupling is able to withstand even high vibration loads.

5. Protection ring

The protection ring (cf. page 12) protects the sealing sleeve from UV rays, fire, etc. and increases the flexural strength of the coupling.

NORMACONNECT® FGR Type series

The NORMACONNECT® product range features the correct coupling for any conceivable application. The current range of pipe couplings comprises the following types:

NORMACONNECT® FGR – for axial non-restraint connections:



NORMACONNECT® FLEX/FLEX E
Axial non-restraint pipe couplings used to connect metal and/or plastic pipes



NORMACONNECT® FLEX 3
Axial non-restraint pipe couplings used to connect metal and/or plastic pipes; extra wide band



NORMACONNECT® REP E
Repair couplings used to connect and seal restrained metal and plastic pipes

NORMACONNECT® FGR – for axial restraint connections:



NORMACONNECT® RFP
Retrofit flame protection for axial restraint and none axial restraint pipe coupling



NORMACONNECT® GRIP/GRIP E
Axial restraint pipe couplings used to connect metal pipes with plastic pipes



NORMACONNECT® GRIPE-FP
Axial restraint pipe couplings with integrated flame protection used to connect metal pipes



**NORMACONNECT® PLAST GRIP/
PLAST GRIP E**
Axial restraint pipe couplings used to connect plastic pipes



**NORMACONNECT® COMBI GRIP/
COMBI GRIP E**
Axial restraint pipe couplings used to connect metal pipes with plastic pipes

Couplings types and suitable applications

Pipes to be joined	RA (mm)	FLEX	FLEX E	FLEX 3	REP E from 35 mm	GRIP	GRIP E	GRIP E-FP
Metal + Metal	26.9 to 163.3	70 to 32 bar	70 to 32 bar	-	60 to 32 bar	70 to 32 bar	70 to 32 bar	60 to 32 bar
	180.0 to 419.0	-	-	-	-	-	-	20 to 6.5 bar
	180.0 to 609.6	-	-	-	-	-	20 to 2 bar	-
	180.0 to 711.2	-	-	-	-	32 to 2.5 bar	-	-
	180.0 to 1219.2	50 to 7 bar	30 to 4 bar	-	30 to 4 bar	-	-	-
	326.0 to 2032.0	-	-	16.5 to 1.5 bar	-	-	-	-
Plastic + Plastic	26.9 to 163.3	16 bar	16 bar	-	16 bar	-	-	-
	180.0 to 1219.2	16 to 7 bar	16 to 4 bar	-	16 to 4 bar	-	-	-
Metal + Plastic	26.9 to 168.3	16 bar	16 bar	-	-	-	-	-
	180.0 to 1219.2	16 to 7 bar	16 to 7 bar	-	-	-	-	-

Pipes to be joined	Size (mm)	PLAST GRIP	PLAST GRIP E	COMBI GRIP	COMBI GRIP E
Plastic + Plastic	40.0 to 406.4	16 to 6 bar	-	-	-
	40.0 to 163.3	-	16 bar	-	-
Metal + Plastic	38/40 to 160/168.3	-	-	16 bar	16 bar
	200/204 to 400/406.4	-	-	16 to 6 bar	-

For pressure values concerning shipbuilding applications, please refer to respective tables.

NORMACONNECT® FGR Materials

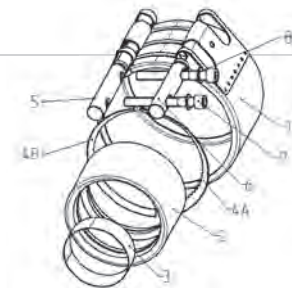

NORMACONNECT® Components and Material Grades as per AISI/BS

NORMACONNECT® pipe couplings are available in the materials W2, W4 and W5.

W2				
No.	Component	FLEX/FLEX E	GRIP/GRIP E	PLAST GRIP/ PLAST GRIP E
1	Housing with bridge	304/304 S31	304/304 S31	304/304 S31
2	Sealing sleeve	EPDM/NBR	EPDM/NBR	EPDM/NBR
3	Strip insert ¹⁾	316Ti/320 S31/PA-GR	316Ti/320 S31/PA-GR	316Ti/320 S31/PA-GR
4 A	Anchoring ring for metal pipes ²⁾	–	301/301 S21	–
4 A	Anchoring ring for plastic pipes ²⁾	–	–	PA-GF-NS ³⁾
4 B	Protection ring	316Ti/320 S31	–	–
5 + 6	Solid locking trunnions	AISI 1213	AISI 1213	AISI 1213
5 + 6	Hollow locking trunnions	AISI 1518	AISI 1518	AISI 1518
7	Locking bolts	10,9	10,9	10,9
8	Washer	A4-80/316	A4-80/316	A4-80/316

W4				
No.	Component	FLEX/FLEX E	GRIP/GRIP E	PLAST GRIP/ PLAST GRIP E
1	Housing with bridge	304/304 S31	304/304 S31	304/304 S31
2	Sealing sleeve	EPDM/NBR	EPDM/NBR	EPDM/NBR
3	Strip insert ¹⁾	316Ti/320 S31/PA-GR	316Ti/320 S31/PA-GR	316Ti/320 S31/PA-GR
4 A	Anchoring ring for metal pipes ²⁾	–	301/301 S21	–
4 A	Anchoring ring for plastic pipes ²⁾	–	–	PA-GF-NS ³⁾
4 B	Protection ring	316Ti/320 S31	–	–
5 + 6	Solid locking trunnions	316L	316L	1.4404
5 + 6	Hollow locking trunnions	316Ti/320 S31	316Ti/320 S31	1.4571
7	Locking bolts	A4-80/316	A4-80/316	A4-80
8	Washer	A4-80/316	A4-80/316	A4-80

W5						
No.	Component	FLEX/FLEX E	GRIP/GRIP E	COMBI GRIP/ COMBI GRIP E	PLAST GRIP/ PLAST GRIP E	REP E
1	Housing	316Ti/320 S31	316Ti/320 S31	316Ti/320 S31	316Ti/320 S31	316Ti/320 S31
2	Sealing sleeve	EPDM/NBR	EPDM/NBR	EPDM/NBR	EPDM/NBR	EPDM/NBR
3	Strip insert ¹⁾	316Ti/320 S31/PA-GR	316Ti/320 S31/PA-GR	316Ti/320 S31/PA-GR	316Ti/320 S31/PA-GR	316Ti/320 S31
4 A	Anchoring ring for metal pipes ²⁾	–	301/301 S21	301/301 S21	–	–
4 A	Anchoring ring for plastic pipes ²⁾	–	–	PA-GF-NS ³⁾	PA-GF-NS ³⁾	–
4 B	Protection ring	316Ti/320 S31	–	–	–	–
5 + 6	Solid locking trunnions	316L	316L	316L	316L	316L
5 + 6	Hollow locking trunnions	316Ti/320 S31	316Ti/320 S31	316Ti/320 S31	316Ti/320 S31	316Ti/320 S31
7	Locking bolts	A4-80/316	A4-80/316	A4-80/316	A4-80/316	A4-80/316
8	Washer	A4-80/316	A4-80/316	A4-80/316	A4-80/316	A4-80/316

¹⁾ PA-GF plastic strip inserts are only for pipe couplings used in shipbuilding applications.

²⁾ COMBI GRIP couplings are equipped with two different anchoring rings (1 x for the metal end, 1 x for the plastic end).

³⁾ PA-GF: PA reinforced with fibre glass; NS: new silver.

Sealing sleeves: Areas of application & temperature resistance

Material of seal	EPDM	NBR
Temperature range	-30 °C up to +125 °C OD 26.9 up to 168,3 mm -20 °C up to +80 °C OD > 180 mm	-20 °C up to +80 °C
Media	Drinking water Alcohols Compressed air Solids	Water Oils Gases (combustible) Fuels Hydrocarbon solutions

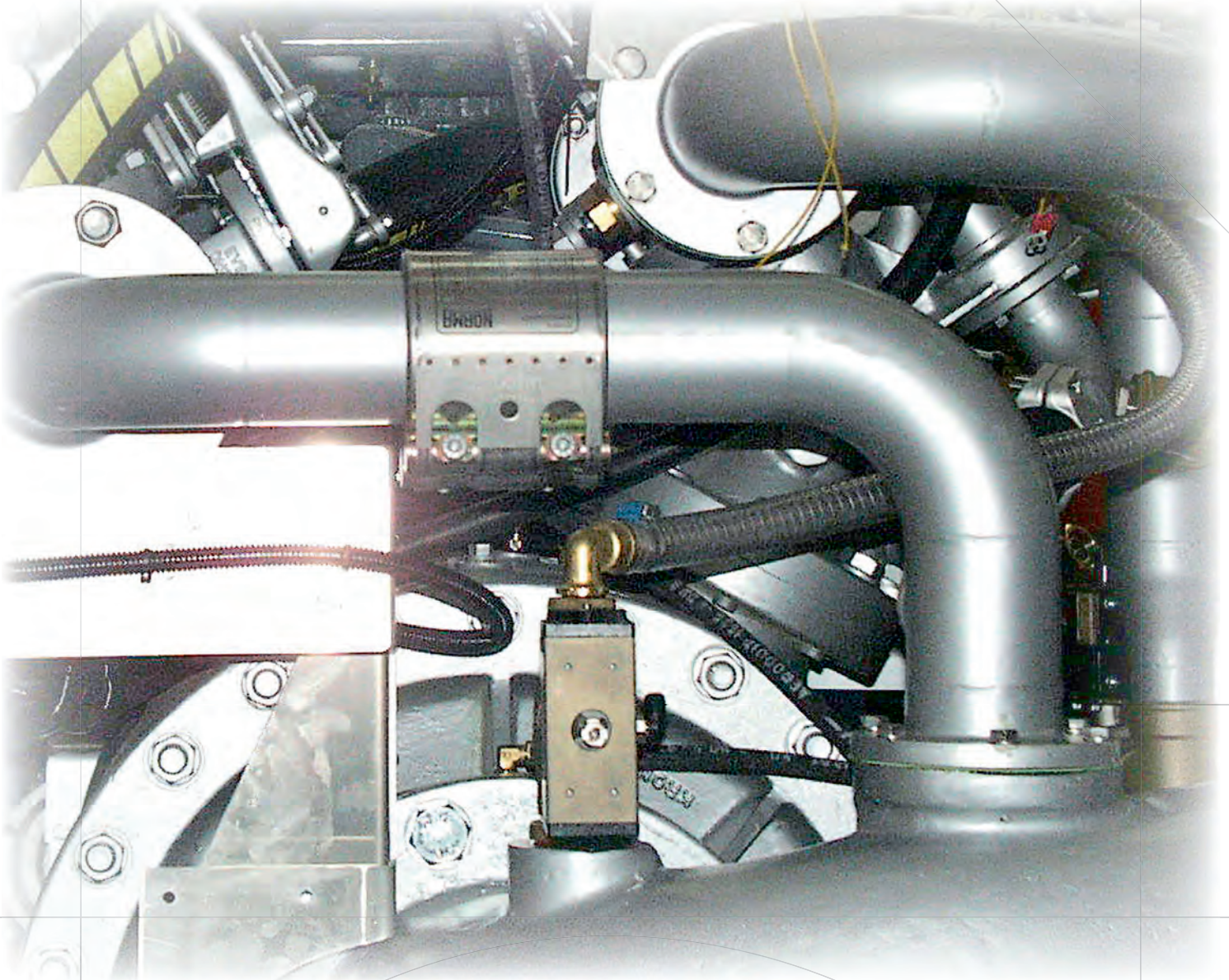

NORMACONNECT® FLEX/FLEX E

The protective pipe coupling

NORMACONNECT® FLEX /FLEX E pipe couplings are used for connecting restrained pipes. Both metal and plastic pipes can be connected safely and quickly. With NORMACONNECT® FLEX/FLEX E pipe couplings sealing reliability is also ensured under the condition of gaps between pipe ends which are compensated. Given outside pipe diameters of > 180 mm the FLEX type is suitable for high pressure and the FLEX E type for low pressure applications.

NORMACONNECT® FLEX /FLEX E Features:

1. Double-lip sealing system*
2. Standard strip insert*
3. Heavy duty lock bars*
5. Protection ring*

* For details refer to Product benefits pages 6–7.



NORMACONNECT®
FLEX E



NORMACONNECT® FLEX

Enquiries/ordering

When making enquiries or placing orders please indicate:

Example:

- | | |
|--|-------|
| 1. The type (FLEX, FLEX E) | FLEX |
| 2. The required material (W2, W4, W5), (cf. page 10) | W2 |
| 3. The pipe outside diameter OD, (cf. table) | 609.6 |
| 4. The sealing sleeve material (EPDM, NBR) | EPDM |

For this example, the order text would read: NORMACONNECT® FLEX – W2 – 609.6 - EPDM

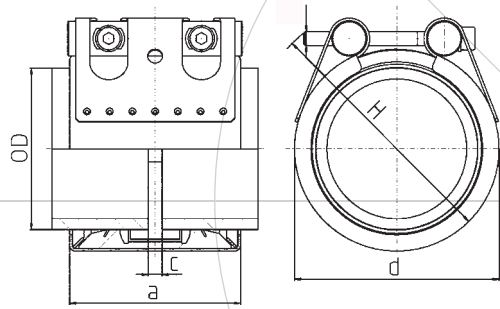

NORMACONNECT® FLEX/FLEX E

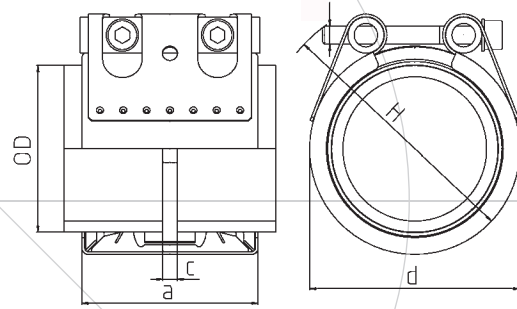

NORMACONNECT® FLEX



NORMACONNECT® FLEX E

OD (mm)	Clamping range ODmin – ODmax (mm)	PN ¹⁾  (bar)	WP ²⁾  (bar)	C _{max} (mm)	Dimensions		
					a (mm)	d clamped approx. (mm)	H approx. (mm)
26.9	26.4 – 27.5	16	70	3	67	50	70
28.0	27.5 – 28.5	16	70	3	67	50	70
30.0	29.5 – 30.6	16	70	3	67	50	70
33.7	33.0 – 34.3	16	60	3	67	55	75
35.0	34.5 – 35.6	16	60	8	63	55	75
38.0	37.5 – 38.6	16	60	8	63	60	80
42.4	41.7 – 43.0	16	50	8	63	65	85
44.5	44.0 – 45.1	16	50	8	63	65	85
48.3	47.6 – 50.5	16	50	8	63	70	90
54.0	53.3 – 54.6	16	50	17	78	75	95
57.0	56.3 – 57.7	16	50	17	78	80	100
60.3	59.5 – 61.0	16	40	17	78	85	105
63.0	62.2 – 63.9	16	40	17	78	85	105
70.0	69.0 – 71.0	16	40	25	98	90	110
73.0	72.1 – 73.8	16	40	25	98	95	115
76.1	75.2 – 77.0	16	35	25	98	100	120
78.0	77.1 – 78.9	16	35	25	98	100	120
80.0	79.0 – 80.8	16	35	25	98	100	120
84.0	83.0 – 85.0	16	35	25	98	105	125
88.9	87.0 – 89.9	16	35	25	98	110	130
101.6	100.4 – 102.8	16	35	25	98	125	145
104.0	102.8 – 106.1	16	35	25	98	125	145
108.0	106.8 – 109.2	16	35	25	98	130	150
110.0	108.8 – 111.4	16	35	25	98	130	150
114.3	113.0 – 115.5	16	35	25	98	135	155
122.0	120.8 – 123.2	16	32	35	113	145	165
129.0	127.6 – 131.1	16	32	35	113	155	185
133.0	131.5 – 134.4	16	32	35	113	160	190
139.7	138.1 – 141.6	16	32	35	113	165	195
141.3	139.6 – 142.8	16	32	35	113	170	200
154.0	152.3 – 156.1	16	32	35	113	180	210
159.0	157.3 – 160.7	16	32	35	113	185	215
168.3	166.5 – 170.1	16	32	35	113	195	225

¹⁾ **PN** (nominal pressure) is the max. admissible working pressure in shipbuilding, based on a safety factor of ≥ 4 .

²⁾ **WP** is the max. working pressure in industrial applications, based on a safety factor as per NORMA specification.

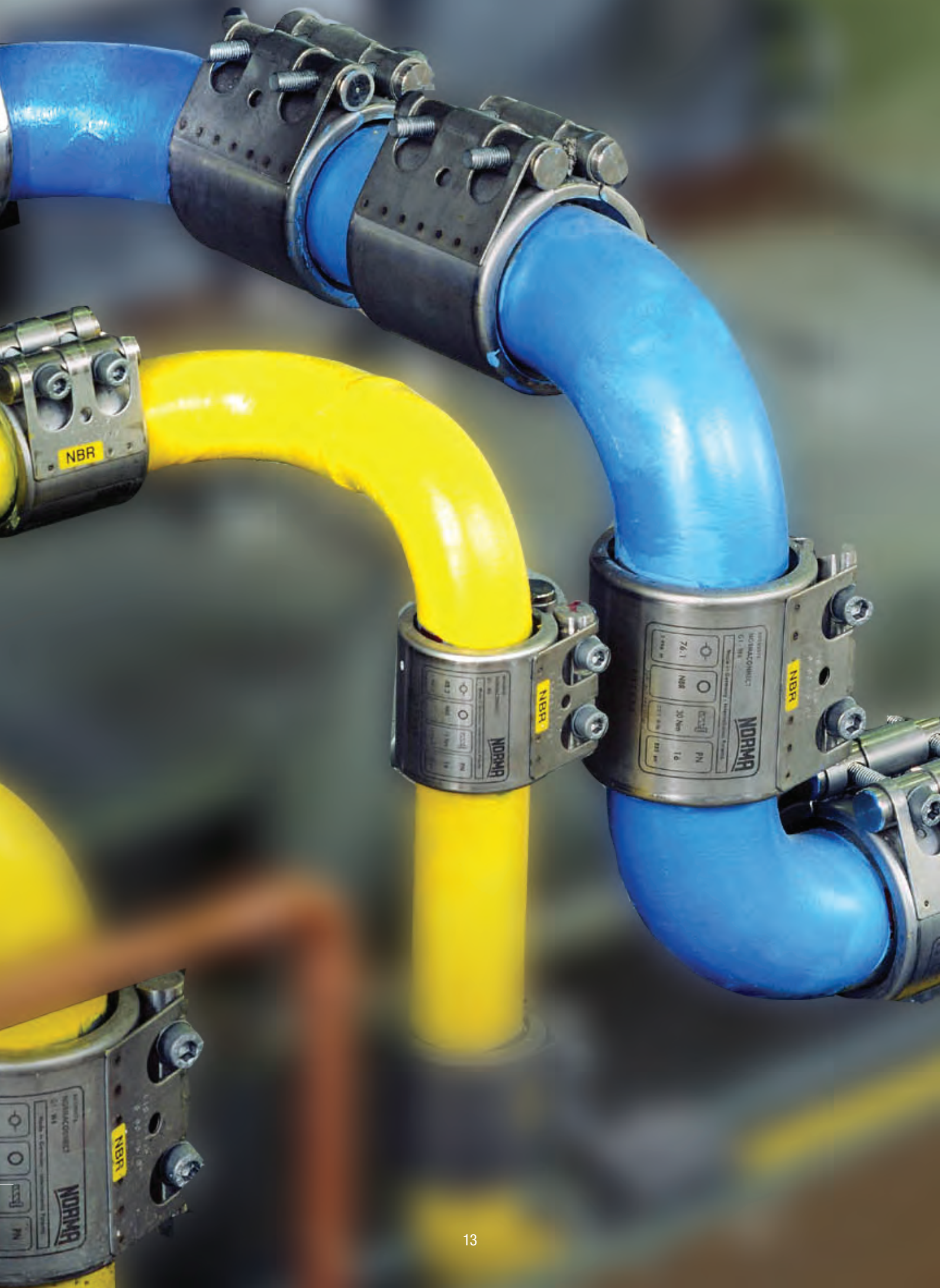

Norma
NORMA
NBR
26.1
30 Nm
1.6
PN

NBR
NORMA
NBR
26.1
30 Nm
1.6
PN

NBR
NORMA
NBR
26.1
30 Nm
1.6
PN

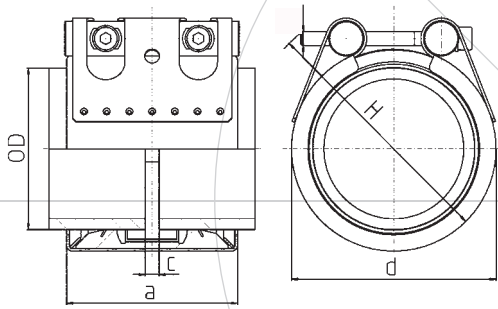

NORMACONNECT® FLEX/FLEX E

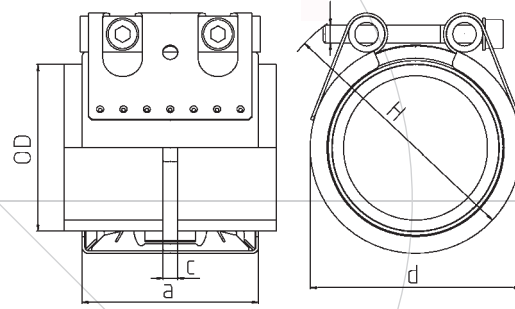

NORMACONNECT® FLEX



NORMACONNECT® FLEX E

OD (mm)	Clamping range ODmin – ODmax (mm)	MAWP ³⁾  (bar)		WP ²⁾  (bar)		C _{max} (mm)	Dimensions				
		FLEX	FLEX E	FLEX	FLEX E		a (mm)		d clamped approx. (mm)	H approx. (mm)	
							FLEX	FLEX E			
180.0	178.0 – 182.0	23.5	13.5	50.0	30.0	35	141	139	210	240	
193.7	192.0 – 196.0	23.5	13.5	46.0	28.0	35	141	139	225	255	
206.0	202.0 – 208.0	20.0	13.5	43.0	26.5	35	141	139	240	270	
219.1	216.0 – 221.0	18.0	13.5	40.5	23.0	35	141	139	250	280	
225.0	222.0 – 227.0	18.0	12.0	40.0	23.0	35	141	139	255	285	
229.9	228.0 – 232.0	18.0	12.0	39.0	23.0	35	141	139	260	290	
244.5	242.0 – 247.0	18.0	12.0	37.0	22.0	35	141	139	275	305	
254.0	250.0 – 256.0	18.0	12.0	35.5	21.0	35	141	139	285	315	
267.0	264.0 – 269.0	18.0	12.0	33.5	20.0	35	141	139	300	330	
273.0	270.0 – 275.0	17.0	12.0	33.0	20.0	35	141	139	305	335	
306.0	302.0 – 308.0	15.0	9.0	29.0	17.5	35	141	139	340	370	
323.9	320.0 – 327.0	15.0	9.0	28.0	17.5	35	141	139	355	385	
326.0	322.0 – 329.0	13.0	9.0	27.5	16.5	35	141	139	360	390	
355.6	352.0 – 359.0	13.0	9.0	25.0	15.0	35	141	139	390	420	
406.4	402.0 – 410.0	10.0	7.5	22.0	14.0	35	141	139	440	470	
429.0	426.0 – 431.0	7.5	5.5	21.0	13.0	35	141	139	460	490	
442.0	439.0 – 444.0	7.5	5.5	20.0	13.0	35	141	139	475	505	
457.2	454.0 – 459.0	7.5	5.5	19.5	12.0	35	141	139	490	520	
508.0	505.0 – 510.0	7.5	5.5	17.0	11.0	35	141	139	540	570	
531.0	528.0 – 534.0	7.5	5.5	16.0	10.5	35	141	139	565	595	
558.8	556.0 – 562.0	7.5	5.5	15.5	10.0	35	141	139	590	620	
609.6	606.0 – 613.0	6.0	4.5	14.0	9.0	35	141	139	640	670	
634.0	631.0 – 637.0	5.0	4.5	13.5	8.0	35	141	139	665	695	
711.2	707.0 – 715.0	5.0	4.0	12.0	7.0	35	141	139	745	775	
762.0	758.0 – 766.0	4.5	3.2	11.0	7.0	35	141	139	795	885	
812.8	808.0 – 817.0	4.5	3.2	10.5	6.5	35	141	139	845	935	
914.4	909.0 – 919.0	3.3	2.0	9.5	5.5	35	141	139	945	1035	
1016.0	1013.0 – 1019.0	3.3	2.0	8.0	5.0	35	141	139	1050	1140	
1117.5	1114.0 – 1120.0	3.3	2.0	7.5	4.5	35	141	139	1150	1240	
1219.2	1216.0 – 1222.0	3.3	2.0	7.0	4.0	35	141	139	1250	1340	

²⁾ WP is the max working pressure in industrial applications, based on a safety factor as per NORMA specification.

³⁾ MAWP (maximum allowable working pressure) is the max. admissible working pressure in shipbuilding, based on a safety factor of ≥ 4 .

For the pipes to be joined the max. difference in diameter must not exceed 5 mm.

All pipe couplings ≥ 800 mm are in 2 parts.

Sizes > 1219.2 mm on request.

Higher pressures on request.

NORMACONNECT® FLEX 3

The pipe coupling with extra wide band

NORMACONNECT® FLEX 3 featuring an extra wide band is an axial non-restraint coupling used to connect metal and/or plastic pipes quickly and safely.

NORMACONNECT® FLEX 3 Features:

- 1. Double-lip sealing system*
- 2. Standard strip insert*
- 3. Heavy duty lock bars*

* For details please refer to Product benefits pages 6–7.



*NORMACONNECT®
FLEX 3 pipe coupling
with extra wide band
width of 211 mm*



*NORMACONNECT®
FLEX 3*

Enquiries/ordering

When making enquiries or placing orders please indicate:

Example:

- | | |
|--|--------|
| 1. The type (FLEX 3) | FLEX 3 |
| 2. The required material (W5), (cf. page 10) | W5 |
| 3. The pipe outside diameter OD, (cf. table) | 609.6 |
| 4. The sealing sleeve material (EPDM, NBR) | EPDM |

For this example, the order text would read: NORMACONNECT® FLEX 3 – W5 – 609.6 - EPDM

NORMACONNECT® FLEX 3

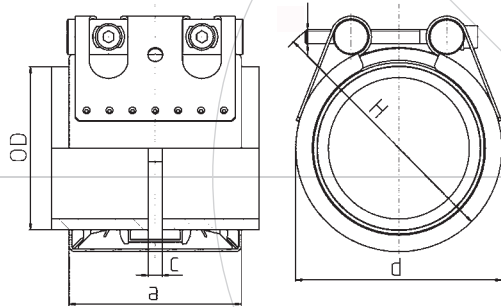

NORMACONNECT® FLEX 3

OD (mm)	Clamping range		WP ¹⁾  (bar)	C _{max} (mm)	Dimensions		
	ODmin (mm)	– ODmax (mm)			a (mm)	clamped approx. (mm)	
						d	H
						approx. (mm)	approx. (mm)
326.0	322.0	– 329.0	16.5	65	211	365	405
355.6	352.0	– 359.0	15.5	65	211	395	435
406.4	402.0	– 410.0	13.5	65	211	445	485
429.0	426.0	– 431.0	12.5	65	211	465	505
442.0	439.0	– 444.0	12.0	65	211	480	520
457.2	454.0	– 459.0	12.0	65	211	495	535
508.0	505.0	– 510.0	10.5	65	211	545	585
531.0	528.0	– 534.0	10.0	65	211	570	610
558.8	556.0	– 562.0	9.5	65	211	595	635
609.6	606.0	– 613.0	9.0	65	211	645	685
634.0	631.0	– 637.0	8.5	65	211	670	710
711.2	707.0	– 715.0	7.5	65	211	750	790
762.0	758.0	– 766.0	7.0	65	211	800	840
812.8	808.0	– 817.0	6.5	65	211	850	890
914.4	909.0	– 919.0	6.0	65	211	950	990
1016.0	1013.0	– 1019.0	5.0	65	211	1055	1095
1117.5	1114.0	– 1120.0	4.5	65	211	1155	1195
1219.2	1216.0	– 1222.0	4.0	65	211	1255	1295
1320.8	1314.0	– 1328.0	3.0	65	211	1360	1400
1422.4	1415.0	– 1430.0	3.0	65	211	1460	1500
1524.0	1516.0	– 1532.0	2.5	65	211	1560	1600
1625.6	1617.0	– 1634.0	2.5	65	211	1665	1705
1727.2	1718.0	– 1736.0	2.0	65	211	1765	1805
1828.8	1819.0	– 1838.0	2.0	65	211	1865	1905
1930.4	1920.0	– 1940.0	2.0	65	211	1970	2010
2032.0	2021.0	– 2042.0	1.5	65	211	2070	2110

¹⁾ **WP** is the max working pressure in industrial applications, based on a safety factor as per NORMA specification.

For the pipes to be joined the max. **difference in diameter** must not exceed 5 mm.

All pipe couplings ≥ 800 mm are in 2 parts.

NORMACONNECT® REP E

The repair coupling

NORMACONNECT® REP E are non-restraint repair couplings. They are used to connect and/or seal damaged metal and plastic pipes. They also enable repairs to be carried out easily, quickly and safely without the need to dismantle the pipes.

NORMACONNECT® REP E Features:

1. Double-lip sealing system*
2. Standard strip insert*

* For details refer to Product benefits pages 6–7.

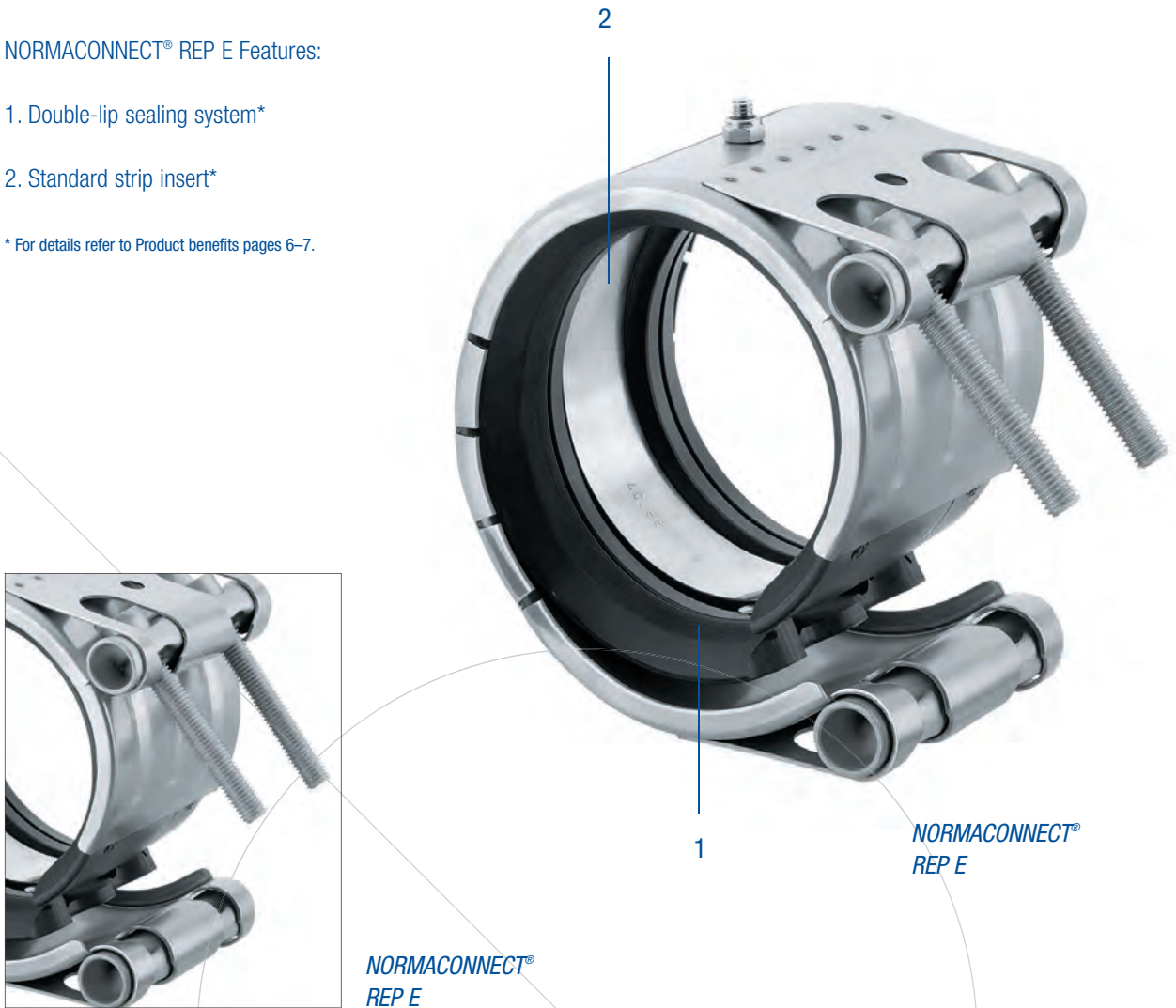

Enquiries/ordering

When making enquiries or placing orders please indicate:

Example:

- | | |
|--|-------|
| 1. The type (REP E) | REP E |
| 2. The required material (W5), (cf. page 10) | W5 |
| 3. The pipe outside diameter OD, (cf. table) | 609.6 |
| 4. The sealing sleeve material (EPDM, NBR) | EPDM |

For this example, the order text would read: NORMACONNECT® REP E – W5 – 609.6 – EPDM

NORMACONNECT® REP E

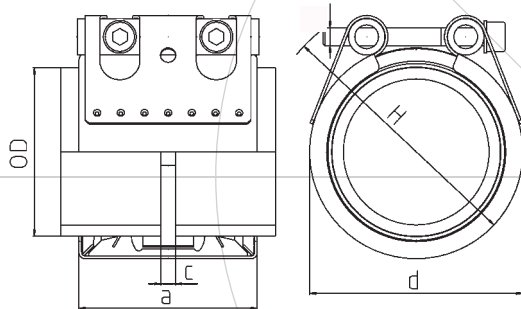

NORMACONNECT® REP E

OD (mm)	Clamping range		WP ¹⁾ (bar)	C _{max} (mm)	Dimensions		
	ODmin (mm)	– ODmax (mm)			a (mm)	d clamped approx. (mm)	H approx. (mm)
35.0	34.5	– 35.6	60	8	63	55	75
38.0	37.5	– 38.6	60	8	63	60	80
42.4	41.7	– 43.0	50	8	63	65	85
44.5	44.0	– 45.1	50	8	63	65	85
48.3	47.6	– 50.5	50	8	63	70	90
54.0	53.3	– 54.6	50	17	78	75	95
57.0	56.3	– 57.7	50	17	78	80	100
60.3	59.5	– 61.0	40	17	78	85	105
63.0	62.2	– 63.9	40	17	78	85	105
70.0	69.0	– 71.0	40	25	98	90	110
73.0	72.1	– 73.8	40	25	98	95	115
76.1	75.2	– 77.0	35	25	98	100	120
78.0	77.1	– 78.9	35	25	98	100	120
80.0	79.0	– 80.8	35	25	98	100	120
84.0	83.0	– 85.0	35	25	98	105	125
88.9	87.0	– 89.9	35	25	98	110	130
98.0	96.9	– 99.0	35	25	98	120	140
101.6	100.4	– 102.8	35	25	98	125	145
104.0	102.8	– 106.1	35	25	98	125	145
108.0	106.8	– 109.2	35	25	98	130	150
110.0	108.8	– 111.4	35	25	98	130	150
114.3	113.0	– 115.5	35	25	98	135	155
122.0	120.8	– 123.2	32	35	113	145	165
129.0	127.6	– 131.1	32	35	113	155	185
133.0	131.5	– 134.4	32	35	113	160	190
139.7	138.1	– 141.6	32	35	113	165	195
141.3	139.6	– 142.8	32	35	113	170	200
154.0	152.3	– 156.1	32	35	113	180	210
159.0	157.3	– 160.7	32	35	113	185	215
168.3	166.5	– 170.1	32	35	113	195	225

¹⁾ WP is the max working pressure in industrial applications, based on a safety factor as per NORMA specification.

NORMACONNECT® REP E

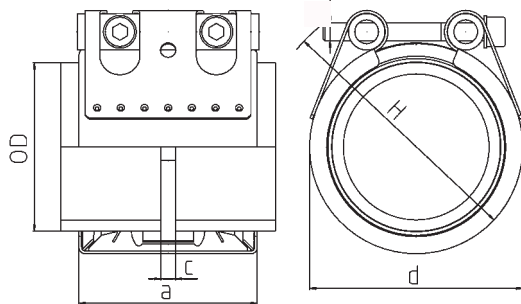

NORMACONNECT® REP E

OD (mm)	Clamping range		WP ¹⁾  (bar)	C _{max} (mm)	Dimensions		
	ODmin (mm)	– ODmax (mm)			a (mm)	d clamped approx. (mm)	H approx. (mm)
180.0	178.0	– 182.0	30.0	35	139	210	240
193.7	192.0	– 196.0	28.0	35	139	225	255
206.0	202.0	– 208.0	26.5	35	139	240	270
219.1	216.0	– 221.0	23.0	35	139	250	280
225.0	222.0	– 227.0	23.0	35	139	255	285
229.9	228.0	– 232.0	23.0	35	139	260	290
244.5	242.0	– 247.0	22.0	35	139	275	305
254.0	250.0	– 256.0	21.0	35	139	285	315
267.0	264.0	– 269.0	20.0	35	139	300	330
273.0	270.0	– 275.0	20.0	35	139	305	335
306.0	302.0	– 308.0	17.5	35	139	340	370
323.9	320.0	– 327.0	17.5	35	139	355	385
326.0	322.0	– 329.0	16.5	35	139	360	390
355.6	352.0	– 359.0	15.0	35	139	390	420
406.4	402.0	– 410.0	14.0	35	139	440	470
429.0	426.0	– 431.0	13.0	35	139	460	490
442.0	439.0	– 444.0	13.0	35	139	475	505
457.2	454.0	– 459.0	12.0	35	139	490	520
508.0	505.0	– 510.0	11.0	35	139	540	570
531.0	528.0	– 534.0	10.5	35	139	565	595
558.8	556.0	– 562.0	10.0	35	139	590	620
609.6	606.0	– 613.0	9.0	35	139	640	670
634.0	631.0	– 637.0	8.0	35	139	665	695
711.2	707.0	– 715.0	7.0	35	139	745	775
762.0	758.0	– 766.0	7.0	35	139	795	825
812.8	808.0	– 817.0	6.5	35	139	845	875
914.4	909.0	– 919.0	5.5	35	139	945	975
1016.0	1013.0	– 1019.0	5.0	35	139	1050	1080
1117.5	1114.0	– 1120.0	4.5	35	139	1150	1180
1219.2	1216.0	– 1222.0	4.0	35	139	1250	1280

¹⁾ WP is the max working pressure in industrial applications, based on a safety factor as per NORMA specification.

Sizes > 1219.2 mm on request.



NORMACONNECT® GRIP/GRIP E

The strong pipe coupling

NORMACONNECT® GRIP/GRIP E axial restraint pipe couplings are used to connect metal pipes. The anchoring ring with conically stamped teeth indents into the pipe surface (steel, stainless steel or cast iron) and provides safe and strong axial restraint. Owing to the special design the coupling can withstand even high vibration loads.

NORMACONNECT® GRIP/GRIP E Features:

1. Double-lip sealing system*
2. Standard strip insert*
3. Heavy duty lock bars*
4. Anchoring ring with conically stamped teeth

* For details refer to Product benefits pages 6–7.

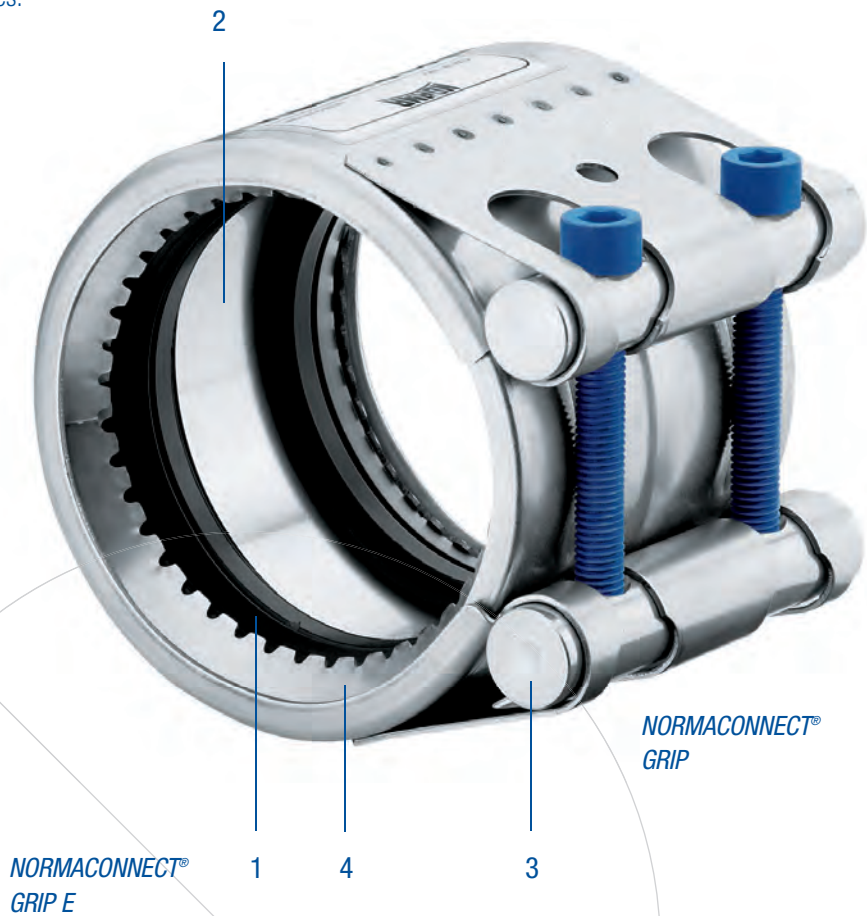

Enquiries/ordering

When making enquiries or placing orders please indicate:

Example:

- | | |
|--|------|
| 1. The type (GRIP/GRIP E) | GRIP |
| 2. The required material (W2,W4,W5), (cf. page 10) | W5 |
| 3. The pipe outside diameter OD, (cf. table) | 88.9 |
| 4. The sealing sleeve material (EPDM, NBR) | EPDM |

For this example, the order text would read: NORMACONNECT® GRIP – W5 – 88.9 – EPDM

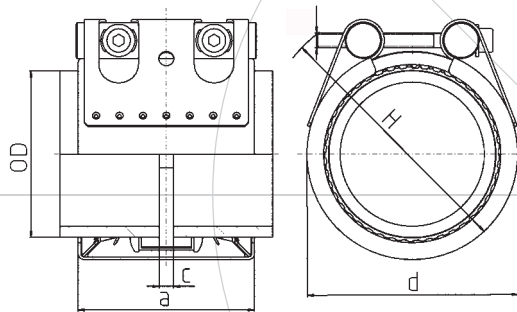

NORMACONNECT® GRIP/GRIP E

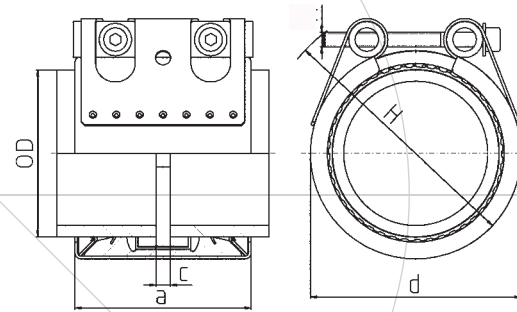

NORMACONNECT® GRIP



NORMACONNECT® GRIP E

OD (mm)	Clamping range ODmin – ODmax (mm)	PN ¹⁾  (bar)	WP ²⁾  (bar)	C _{max} (mm)	Dimensions		
					a (mm)	d clamped approx. (mm)	H approx. (mm)
26.9	26.4 – 27.5	16	70	3	67	50	70
28.0	27.5 – 28.5	16	70	3	67	50	70
30.0	29.5 – 30.6	16	70	3	67	50	70
33.7	33.0 – 34.3	16	60	3	67	55	75
35.0	34.5 – 35.6	16	60	8	63	55	75
38.0	37.5 – 38.6	16	60	8	63	60	80
42.4	41.7 – 43.0	16	50	8	63	65	85
44.5	44.0 – 45.1	16	50	8	63	65	85
48.3	47.6 – 50.5	16	50	8	63	70	90
54.0	53.3 – 54.6	16	50	17	78	75	95
57.0	56.3 – 57.7	16	50	17	78	80	100
60.3	59.5 – 61.0	16	40	17	78	85	105
63.0	62.2 – 63.9	16	40	17	78	85	105
70.0	69.0 – 71.0	16	40	25	98	90	110
73.0	72.1 – 73.8	16	40	25	98	95	115
76.1	75.2 – 77.0	16	35	25	98	100	120
78.0	77.1 – 78.9	16	35	25	98	100	120
80.0	79.0 – 80.8	16	35	25	98	100	120
84.0	83.0 – 85.0	16	35	25	98	105	125
88.9	87.0 – 89.9	16	35	25	98	110	130
101.6	100.4 – 102.8	16	35	25	98	125	145
104.0	102.8 – 106.1	16	35	25	98	125	145
110.0	108.8 – 111.4	16	35	25	98	130	150
114.3	113.0 – 115.5	16	35	25	98	135	155
122.0	120.8 – 123.2	16	32	35	115	145	165
129.0	127.6 – 131.1	16	32	35	115	155	185
133.0	131.5 – 134.4	16	32	35	115	160	190
139.7	138.1 – 141.6	16	32	35	115	165	195
141.3	139.6 – 142.8	16	32	35	115	170	200
154.0	152.3 – 156.1	16	32	35	115	180	210
159.0	157.3 – 160.7	16	32	35	115	185	215
168.3	166.5 – 170.1	16	32	35	115	195	225

¹⁾ PN (nominal pressure) is the max. admissible working pressure in shipbuilding, based on a safety factor of ≥ 4 .

²⁾ WP is the max. working pressure in industrial applications, based on a safety factor as per NORMA specification.

NORMACONNECT® GRIP/GRIP E

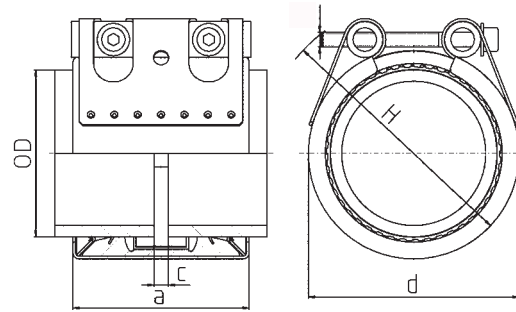
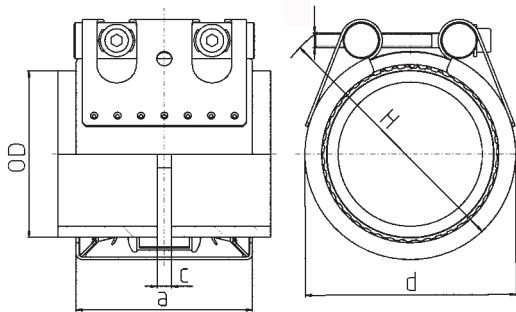

NORMACONNECT® GRIP

NORMACONNECT® GRIP E

OD (mm)	Clamping range ODmin – ODmax (mm)	MAWP ¹⁾ (bar)		WP ²⁾ (bar)		C _{max} (mm)	Dimensions				
		GRIP	GRIP E	GRIP	GRIP E		a (mm)		d clamped approx. (mm)		H approx. (mm)
193.7	192.0 – 196.0	16.0	10.0	32.0	20.0	35	142	141	225	255	
206.0	202.0 – 208.0	16.0	10.0	32.0	20.0	35	142	141	240	270	
219.1	216.0 – 221.0	16.0	10.0	32.0	20.0	35	142	141	250	280	
225.0	222.0 – 227.0	13.0	10.0	26.5	16.0	35	142	140	255	285	
229.9	228.0 – 232.0	13.0	5.5	26.0	16.0	35	142	140	260	290	
244.5	242.0 – 247.0	12.0	5.5	24.5	15.0	35	142	140	275	305	
254.0	250.0 – 256.0	11.5	5.5	22.5	14.0	35	142	140	285	315	
267.0	264.0 – 269.0	11.0	5.5	22.5	13.5	35	142	140	300	330	
273.0	270.0 – 275.0	11.0	5.5	22.0	13.0	35	142	140	305	335	
306.0	302.0 – 308.0	9.5	5.5	19.5	10.5	35	142	140	340	370	
323.9	320.0 – 327.0	6.5	3.0	13.0	9.5	35	142	140	355	385	
326.0	322.0 – 329.0	6.5	3.0	13.0	9.5	35	142	140	360	390	
355.6	352.0 – 359.0	6.0	2.7	12.0	8.5	35	142	140	390	420	
406.4	402.0 – 410.0	4.5	2.5	9.0	7.0	35	142	140	440	470	
429.0	426.0 – 431.0	4.0	2.5	8.5	6.5	35	142	140	460	490	
442.0	439.0 – 444.0	4.0	2.5	8.0	6.5	35	142	140	475	505	
457.2	454.0 – 459.0	4.0	2.5	8.0	6.0	35	142	140	490	520	
508.0	505.0 – 510.0	2.5	2.0	5.0	4.0	35	142	140	540	570	
531.0	528.0 – 534.0	2.5	1.5	5.0	4.0	35	142	140	565	595	
558.8	556.0 – 562.0	2.0	1.5	4.5	3.5	35	142	140	590	620	
609.6	606.0 – 613.0	1.5	1.0	3.0	2.0	35	142	140	640	670	
634.0	631.0 – 637.0	1.5	---	3.0	---	35	142	---	665	695	
711.2	707.0 – 715.0	1.5	---	2.5	---	35	142	---	745	775	

¹⁾ MAWP (maximum allowable working pressure) is the max. admissible working pressure in shipbuilding, based on a safety factor of ≥ 4 .

²⁾ WP is the max working pressure in industrial applications, based on a safety factor as per NORMA specification.

For the pipes to be joined the max. difference in diameter must not exceed 5 mm.



NORMACONNECT® GRIP E-FP

The fire resistant Coupling

NORMACONNECT® GRIP E-FP pipe couplings with integrated flame protection are used with applications in the marine sector (civil and military) as well as in sprinkler systems. For this purpose the GRIP E type has been equipped with an additional housing made from stainless steel plus a fire-resistant lining which can resist temperatures of up to 850°C. The pipe coupling meets the newest VdS directives, IACS P2.11 and ISO 19921/22. Pressures and dimensions on request. Sizes from 26,9 mm up to 323,9 mm.

NORMACONNECT® GRIP E-FP Features:

1. Double-lip sealing system*
2. Standard strip insert*
4. Conically stamped anchoring ring*

* For details refer to Product benefits pages 6–7.

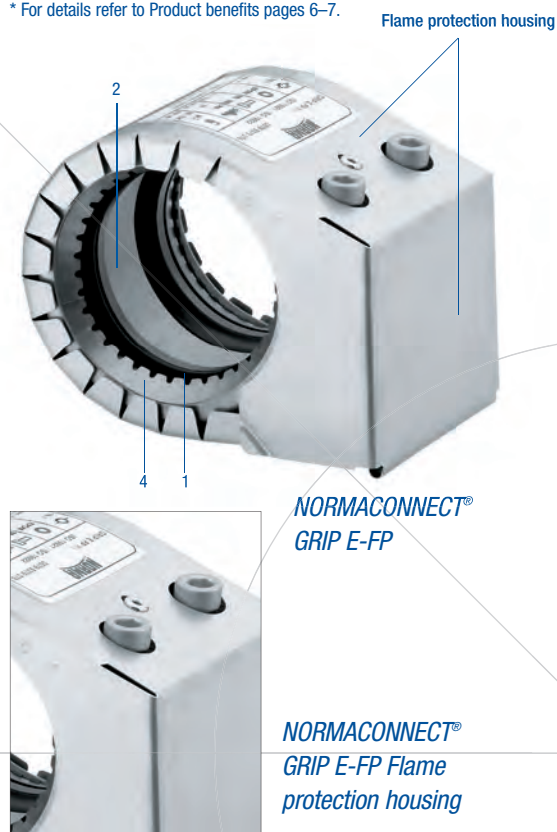

NORMACONNECT® RFP

RFP for application at shipbuilding

The NEW NORMACONNECT® RFP is a retrofittable flame protection housing that has been specially designed for use with all NORMACONNECT® FLEX, GRIP and REP pipe couplings. Its low weight and straightforward design allows quick, easy assembly without any tools and the built-in flame resistant mineral fibre mat provides a premium level of flame protection. The new Retrofit Flame Protection (RFP) housing has been extensively tested and is approved by Germanischer Lloyd: Bureau Veritas, American Bureau of Shipping, Det Norske Veritas, Korean Register of Shipping, Russian Maritime Register of Shipping, Polski Rejestr Statkon and Nippon Kaiji Kyokai / Class NK.

- Flame resistant up to 850°C
- Retrofittable
- Easy assembly without tooling
- Low weight
- Meets IACS requirements
- No chemicals in flame protection mat
- High flexibility
- Clear identification whether coupling is flame protected or not
- Mechanical stress resistant
- Less warehousing costs
- Sizes from 26,9 mm up to 323,9 mm.

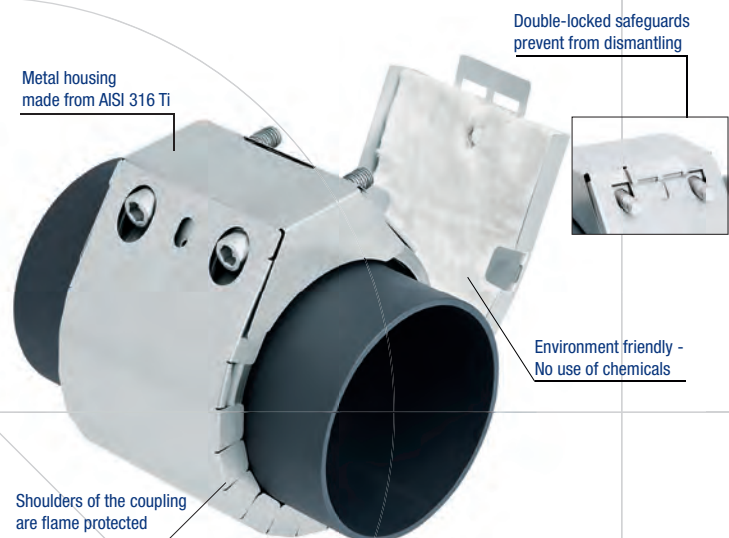

Enquiries/ordering

When making enquiries or placing orders please indicate
(Available in sizes 26.9 up to 323.9 mm):

- | | |
|--|-----------|
| 1. The type (GRIP E-FP) | GRIP E-FP |
| 2. The required material (W5), (cf. page 10) | W5 |
| 3. The pipe outside diameter OD, (cf. table) | 406.4 |
| 4. The sealing sleeve material (EPDM, NBR) | EPDM |

For this example, the order text would read: NORMACONNECT® GRIP E-FP – W5 – 406.4 – EPDM



NORMACONNECT® PLAST GRIP / PLAST GRIP E

The coupling for plastic pipes

NORMACONNECT® PLAST GRIP / PLAST GRIP E axial restraint pipe couplings are used to connect plastic pipes. The specially designed anchoring ring featuring flat rows of teeth engages into the pipe surface without damaging the plastic material. The force applied is distributed evenly across the pipe surface.

NORMACONNECT® PLAST GRIP / PLAST GRIP E Features:

1. Double-lip sealing system*
2. Standard strip insert*
3. Anchoring ring*

* For details refer to Product benefits pages 6–7.

6. Optional support sleeve

When joining plastic pipes made from PE and PP a support sleeve must be used. If the pipes to be joined are made from soft thermoplastic material (e. g. PE) the use of a support sleeve is mandatory. The support sleeve is inserted into the pipe end within the area to be joined and thus protects the pipe from being deformed.



Enquiries/ordering

When making enquiries or placing orders please indicate:

Example:

- | | |
|--|------------|
| 1. The type (PLAST GRIP/PLAST GRIP E) | PLAST GRIP |
| 2. The required material (W2, W5), (cf. page 10) | W5 |
| 3. The pipe outside diameter OD, (cf. table) | 90 |
| 4. The sealing sleeve material (EPDM, NBR) | EPDM |

For this example, the order text would read: NORMACONNECT® PLAST GRIP – W5 – 90 – EPDM

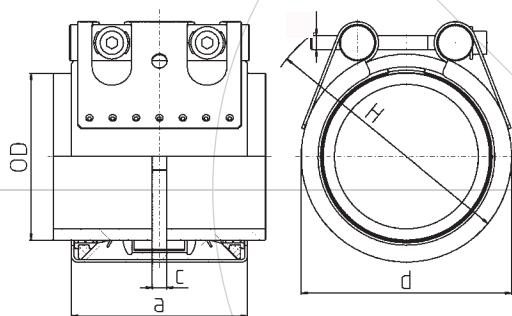

NORMACONNECT® PLAST GRIP / PLAST GRIP E

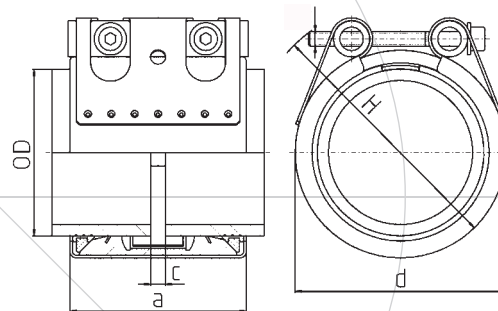

NORMACONNECT® PLAST GRIP



NORMACONNECT® PLAST GRIP E

OD (mm)	Clamping range ODmin – ODmax Plastics (mm)	PN ¹⁾  (bar)	WP ²⁾  (bar)	C _{max} (mm)	Dimensions		
					a (mm)	d clamped approx. (mm)	H approx. (mm)
40.0	39.0 – 40.5	10	16	8	62	60	80
42.4	41.7 – 43.0	10	16	8	62	65	85
48.3	47.6 – 49.5	10	16	8	62	70	90
50.0	49.0 – 50.5	10	16	8	62	70	90
60.3	59.5 – 61.0	10	16	17	78	85	105
63.0	62.0 – 63.5	10	16	17	78	85	105
73.0	72.0 – 74.0	10	16	25	98	95	115
75.0	74.0 – 76.0	10	16	25	98	100	120
76.0	75.0 – 77.0	10	16	25	98	100	120
88.9	88.0 – 90.0	10	16	25	98	110	130
90.0	89.0 – 91.0	10	16	25	98	110	130
101.6	100.4 – 102.8	10	16	25	98	125	145
110.0	109.0 – 111.0	10	16	25	98	130	150
114.3	113.0 – 115.5	10	16	25	98	135	155
140.0	139.0 – 141.0	10	16	35	115	160	180
141.3	138.1 – 141.6	10	16	35	115	165	185
160.0	159.0 – 162.0	10	16	35	115	180	200
168.3	166.5 – 170.1	10	16	35	115	190	210
180.0	178.0 – 182.0	-	16	35	142	210	240
200.0	198.0 – 202.0	-	16	35	142	230	260
219.1	217.0 – 222.0	-	16	35	142	250	280
225.0	222.0 – 227.0	-	10	35	142	255	285
250.0	247.0 – 253.0	-	10	35	142	280	310
273.0	271.0 – 276.0	-	10	35	142	305	335
280.0	277.0 – 283.0	-	10	35	142	310	340
315.0	311.0 – 318.0	-	10	35	142	345	375
323.9	320.0 – 327.0	-	6	35	142	355	385
355.0	352.0 – 359.0	-	6	35	142	385	415
400.0	396.0 – 404.0	-	6	35	142	430	460
406.4	402.0 – 410.0	-	6	35	142	440	470

Note Plast Grip E version (with hollow trunnions) only available up to size 168,3 mm; bigger sizes up to 406,4 mm are Plast Grip version (with solid trunnions).

¹⁾ **PN** (nominal pressure) is the max. admissible working pressure in shipbuilding, based on a safety factor of ≥ 4 .

²⁾ **WP** is the max. working pressure in industrial applications, based on a safety factor as per NORMA specification.

NORMACONNECT® COMBI GRIP / COMBI GRIP E

The combining pipe coupling

NORMACONNECT® COMBI GRIP/COMBI GRIP E axial restraint pipe couplings are used to connect plastic pipes with metal pipes. For the plastic pipe the coupling features on one side a special anchoring ring with rows of flat teeth which are pressed into the pipe surface without damaging the material. At the same time the force applied is distributed evenly across the pipe surface. For the metal pipe the coupling features on the other side an anchoring ring with conically stamped teeth which grip into the pipe surface. Due to the special design of the anchoring ring the coupling can withstand even high vibration loads.

NORMACONNECT® COMBI GRIP/COMBI GRIP E Features:

1. Double-lip sealing system*
2. Standard strip insert*
3. Anchoring ring*

* For details refer to Product benefits pages 6–7.

6. Optional support sleeve

When joining plastic pipes made from PE and PP a support sleeve must be used. If the pipes to be joined are made from soft thermoplastic material (e. g. PE) the use of a support sleeve is mandatory. The support sleeve is inserted into the pipe end within the area to be joined and thus protects the pipe from being deformed.

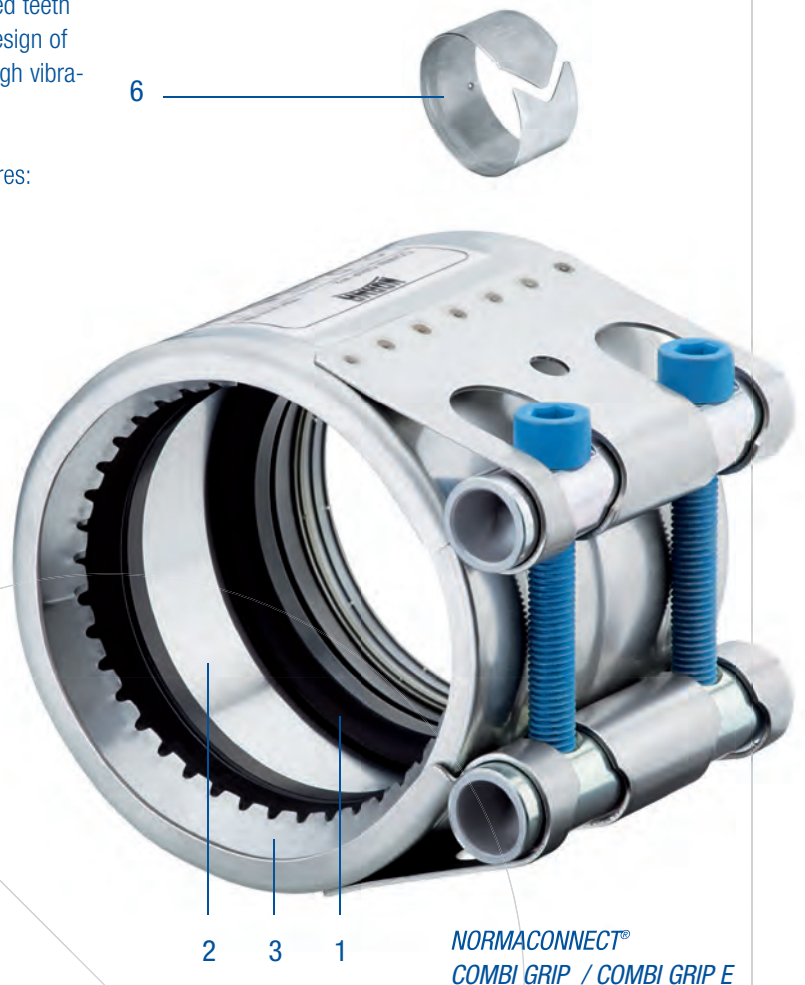

Enquiries/ordering

When making enquiries or placing orders please indicate:

Example:

- | | |
|--|------------|
| 1. The type (COMBI GRIP/COMBI GRIP E) | COMBI GRIP |
| 2. The required material (W2, W5), (cf. page 10) | W5 |
| 3. The pipe outside diameter OD, (cf. table) | 88.9/90 |
| 4. The sealing sleeve material (EPDM, NBR) | EPDM |

For this example, the order text would read: NORMACONNECT® COMBI GRIP – W5 – 88.9 – EPDM

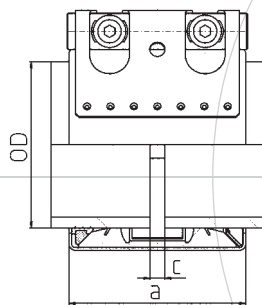

NORMACONNECT® COMBI GRIP / COMBI GRIP E

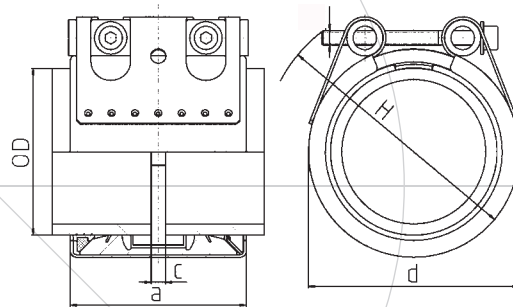

NORMACONNECT® COMBI GRIP



NORMACONNECT® COMBI GRIP E

OD COMBI GRIP/COMBI GRIP E (mm)	Clamping range Plastics (mm)		Clamping range Metal (mm)		PN ¹⁾  (bar)	WP ²⁾  (bar)	C _{max} (mm)	Dimensions		
	ODmin	ODmax	ODmin	ODmax				a (mm)	d clamped approx. (mm)	H approx. (mm)
40.0/38.0	39.0	40.5	37.5	38.6	10	16	8	62	60	80
40.0/42.4	39.0	40.5	41.7	43.0	10	16	8	62	65	85
42.4/42.4	41.7	43.0	41.7	43.0	10	16	8	62	65	85
48.3/48.3	47.6	50.5	47.6	50.5	10	16	8	62	70	90
50.0/48.3	49.0	50.5	47.6	50.5	10	16	8	62	70	90
60.3/60.3	59.5	61.0	59.5	61.0	10	16	17	78	85	105
63.0/60.3	62.0	63.5	59.5	61.0	10	16	17	78	85	105
73.0/73.0	72.0	74.0	72.1	73.8	10	16	25	98	95	115
75.0/76.1	74.0	76.0	75.2	77.0	10	16	25	98	100	120
88.9/88.9	88.0	90.0	87.0	89.9	10	16	25	98	110	130
90.0/88.9	89.0	91.0	87.0	89.9	10	16	25	98	110	130
101.6/101.6	100.4	102.8	100.4	102.8	10	16	25	98	125	145
110.0/108.0	109.0	111.0	106.8	109.2	10	16	25	98	130	150
110.0/114.3	109.0	111.0	113.0	115.5	10	16	25	98	135	155
114.3/114.3	113.0	115.5	113.0	115.5	10	16	25	98	135	155
125.0/129.0	124.0	126.0	127.6	131.1	10	16	35	115	150	170
140.0/139.7	139.0	141.0	138.1	141.6	10	16	35	115	160	180
141.3/141.3	138.1	141.6	139.6	142.8	10	16	35	115	165	185
160.0/159.0	159.0	162.0	157.3	160.7	10	16	35	115	180	200
168.3/168.3	166.5	170.1	166.5	170.1	10	16	35	115	190	210
200.0/204.0	198.0	202.0	202.0	206.0	-	16	35	142	235	265
219.1/219.1	217.0	222.0	216.0	221.0	-	16	35	142	250	280
225.0/219.1	222.0	227.0	216.0	221.0	-	10	35	142	255	285
225.0/222.0	222.0	227.0	220.0	224.0	-	10	35	142	255	285
250.0/254.0	247.0	253.0	250.0	256.0	-	10	35	142	285	315
273.0/273.0	271.0	276.0	270.0	275.0	-	10	35	142	305	335
280.0/273.0	277.0	283.0	270.0	275.0	-	10	35	142	310	340
323.9/323.9	320.0	327.0	320.0	327.0	-	6	35	142	355	385
355.0/355.6	351.0	359.0	352.0	359.0	-	6	35	142	390	420
400.0/406.4	396.0	404.0	402.0	410.0	-	6	35	142	440	470
406.0/406.4	402.0	410.0	402.0	410.0	-	6	35	142	440	470

Note Combi Grip E version (with hollow trunnions) only available up to size 168,3 mm; bigger sizes up to 406,4 mm are Combi Grip version (with solid trunnions).

¹⁾ **PN** (nominal pressure) is the max. admissible working pressure in shipbuilding, based on a safety factor of ≥ 4 .

²⁾ **WP** is the max. working pressure in industrial applications, based on a safety factor as per NORMA specification.

NORMACONNECT® FGR Accessories



Support sleeve

To be used with NORMACONNECT® PLAST GRIP/PLAST GRIP E, COMBI GRIP/COMBI GRIP E in W5 (1.4571) material. For copper and CuNiFe pipes an optional support sleeve made from brass is available on request.

	S-3.2 (SDR 7.5)	S-4 (SDR 9)	S-5 (SDR 11)	S-6.3 (SDR 13.6)	
Ø OD mm	Ø di* mm	Ø di* mm	Ø di* mm	Ø di* mm	VPE
40	29	31	32.6	34	10
50	36	38.8	40.8	42.6	10
63	45.6	48.8	51.4	53.6	10
75	54.4	58.2	61.4	64	10
90	65.4	69.5	73.6	76.8	10
110	79.5	85.4	90	93.8	10
125	91	97	102.2	106.6	5
140	102.2	108.6	114.6	119.4	5
160	116.2	124.2	130.8	136.4	5

* Additional diameters on request.

	S-8 (SDR 17)	S-10 (SDR 21)	S-12.5 (SDR 26)	S-16 (SDR 33)	
Ø OD mm	Ø di* mm	Ø di* mm	Ø di* mm	Ø di* mm	VPE
40	35.2	-	36	-	10
50	44	45.6	46	-	10
63	55.4	57	58.2	59	10
75	66	67.8	69.5	70.4	10
90	79.5	81.4	83	84.4	10
110	96.8	99.4	101.6	103.2	10
125	110.2	113	115.4	117.2	5
140	123.4	126.6	129.2	131.4	5
160	141	144.6	147.6	150.2	5

* Additional diameters on request.

Fitting pliers/fitting belt

for NORMACONNECT® REP E

Ø OD mm	Text for ordering
38-168.3 mm	Fitting pliers for REP E
180-1200 mm	Fitting belt for REP E

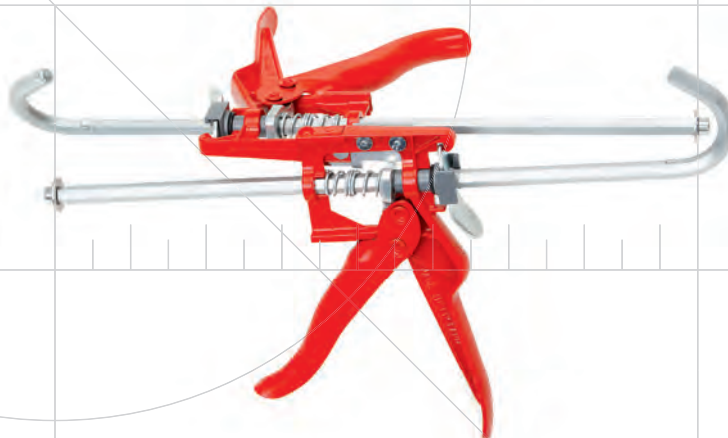

NORMA® – Subsidiary

AUSTRALIA

NORMA Pacific Pty. Ltd.
85 Merrindale Drive
South Croydon, Vict. 3136
Tel.: +61 3 9761 4416
Fax: +61 3 9761 4030
info.au@normagroup.com

CHINA

NORMA China Co., Ltd.
Unit 2102, Landmark Tower 2
8 North Dongsanhuan Road
German Centre
CN-100004 Beijing
Tel.: +86 10 6590 0198
Fax: +86 10 6590 0098
info.cn@normagroup.com

FRANCE

NORMA Distribution France S.A.S.
20 Rue Gustave Eiffel
B.P. 25
Z.A.C. de la Croix-Saint-Nicolas
FR-94510 La Queue en Brie
Tel.: +33 1 45 93 18 19
Fax: +33 1 45 94 89 39
info.fr@normagroup.com

ITALY

NORMA ITALIA SPA
Via Dell'Artigianato 16-18
Z.I. Loc. BOLINA
25085 GAVARDO (BS)
ITALY
Tel.: +39 0365 31141 / +39 0365 31142
Fax: +39 0365 373420
info.it@normagroup.com

MALAYSIA

Norma Pacific (Asia) Pte. Ltd.
(Representative Office)
No. 151-3-5A, Wisma Mutiara Puchong
6th Mile, Jalan Puchong
58200 Kuala Lumpur
Tel.: +60 03 7781 2175
Fax: +60 03 7781 2175
jng@norma.com.sg

SINGAPORE

NORMA Pacific (Asia) Pte Ltd.
Block 207, Woodlands Avenue 9
Woodlands Spectrum II, #06-56
Singapore 738955
Tel.: +65 6759 7955
Mobile: +65 9152 7162
Fax: +65 6759 8092
info.sg@normagroup.com

SPAIN

FIJACIONES NORMA S.A.
Narcis Monturiol, 116-118
E-08902 L'Hospitalet de Llobregat
Tel.: +34 93 432 9955
Fax: +34 93 432 0026
info.es@normagroup.com

THAILAND

Inter Business Alliance Co LTD
NORMA Pacific
208 Soi Rungsit-Nakornnayok 50
Rungsit-Nakornnayok Rd
Prachatipat, Tanyaburi
Patumtani 12130
Thailand
Tel.: +66 02 533 0745
Fax: +66 02 974 0978
sales.sg@normagroup.com

UNITED KINGDOM

NORMA UK Limited
Weber Road, New Greenham Park
GB-Newbury, Berkshire RG19 6HW
Tel.: +44 1635 521880
Fax: +44 1635 57403
info.uk@normagroup.com

Clamp All

2430 East Walton Blvd.
Auburn Hills, MI 48326
Tel.: + 800 762 7255
Fax: + 248 373 3068

JAPAN

NORMA Japan Inc
Shin Osaka Business Zone
Sanbankan
1F, 14-20, Nishinakajima
3-Chome, Yodogawa-Ku
Osaka 532 0011 Japan
Tel.: +81(0)6 6307 2458
Fax: +81(0)6 6307 2457
info.jp@normagroup.com

Tokyo Sales Office
4-3 Kandasurugakai
3 Chome, Chiyoda-Ku
Tokyo, 101 0062 Japan
Tel.: +81(0)3 6206 8370
Fax: +81(0)3 6206 8371
info.jp@normagroup.com

INDIA

NORMA Group Products India PVT.LTD
S. No 662, Talegaon Dadhade
Old Pune Mumbai Road
Pune 410506, INDIA
Tel: +91 99237 96186
Fax:+91 2114 223412
info.in@normagroup.com

NORMA® – Subsidiary

TURKEY

NORMA Turkey
Çayırçimen Sok. Emlak Bankasi Bloklari A-2 Blok, Kat1
Daire 5
LEVENT 34330
Istanbul, TURKEY
Tel.: +90 212 269 0020
Fax: +90 212 278 5511
please do it: info_tr@normagroup.com

MEXICO

NORMA Group Mexico, S. de. R.L de C.V.
Avenida Aristoteles 201
Parque Industrial Kalos
Apodaca, Nuevo Leon, 66600
Mexico
Tel.: +52 81 1247-5770
Fax: +52 81 1247-5776
info.mx@normagroup.com

RUSSIA

NORMA -CIS
445044, Russian Federation
Samara region, Togliatty
Sevemaya St., 25, P.O. Box 2928
Tel.: +7 8482 422 346
Fax: +7 8482 422 347
info.ru@normagroup.com

NORMA® – Worldwide

SOUTH AFRICA

International Clamps (Pty) Ltd
P.O. Box 581
SA-2012 Bergvlei
Tel.: +27 11 809 6500
Fax: +27 11 887 7458
norma@icclamps.co.za
www.icelamps.co.za

SWITZERLA ND

Georg Fischer +GF+
Georg Fischer Rohrleitungssysteme
(Schweiz) AG
CH-8201 Schaffhausen
Tel.: +41 52 6313026
Fax: +41 52 6312897
info@rohrleitungssysteme.georgfischer.ch
www.piping.georgfischer.ch

SYRIA

Nercess S. Karamanoukian
P.O. Box 5204
Aleppo
Tel.: +963 21 2240 658
Fax: +963 21 2242 227
nerkar@net.sy

UNITED ARAB EMIRATES

Arwani Trading Est.
P.O. Box 8783
Dubai
Tel.: +971 4 28 28 223
Fax: +971 4 28 28 207
arwanimk@emirates.net.ae

NORMACONNECT® FGR – Distribution partners worldwide

SALES OFFICES AND DISTRIBUTION PARTNERS WORLDWIDE

The following sales offices/distribution partners are prepared to offer specialist advice regarding the NORMACONNECT® product range.

AUSTRIA

NIROTEC Aschl GmbH
Geisensheim 6
A-4632 Pichl bei Wels
Tel.: +43 7247 87 78
Fax: +43 7247 80 05
nirotec@netway.at
www.nirotec.at

BELGIUM

A.D.R. SPRL/BVBA
Genaustraaf 6
B-2000 Antwerpen
Tel.: +32 3 233 57 61
Fax: +32 3 233 57 71
sales@adr.be
www.adr.be

CZECH REPUBLIC

MATPRO
Kladenská 497
CZ-278 01 Kralupy n. Vlt. III
Tel.: +42 315 722 332 3
Fax: +42 315 722 444
info@matpro.cz

DENMARK

Brd. Klee
Gadagervej 11
P.O. Box 7
DK-2620 Albertslund
Tel.: +45 4386 8333
Fax: +45 4386 8388
klee@brd-klee.dk

FINLAND

RAMATOR Oy
Kärsämäentie 35
FIN-203601 Turku
Tel.: +358 (0)10 835 3000
Fax: +358 (0)10 835 3010
timo.kairama@ramator.fi
www.ramator.fi

GREECE

S.A. Spyrou
Frangon Str. 22
GR-54625 Thessaloniki
Tel.: +30 31 532 900 + 974
Fax: +30 31 531 313
spyrstam@spark.net.gr

HUNGARY

Norma-Ker Kft.
Temesvár u. 19-21
H-1116 Budapest
P.O. Box 29
H-1509 Budapest
Tel.: +36 1/204 7940
Fax: +36 1/204 7941
norma@matavnet.hu

NETHERLANDS

Georg Fischer WAGA N.V.
Lange Veenteweg 19
NL-8161 PA Epe
P.O. Box 290
NL-8160 AG Epe
Tel.: +31 578 678 378
Fax: +31 578 620 848
sales@waga.nl
www.waga.nl

Schiffsbau und Offshore
Manfred J. Niemann Nederland B.V.
Printerweg 7
NL-3821 Amersfoort
Tel.: +31 33 4508200
Fax: +31 33 4560541
info@niemet.nl
www.niemet.nl

POLAND

Variant S.A
ul. Czerwieńskiego 3b
31-319 Kraków
Tel.: +48 12 636 99 44
Fax: +48 12 637 26 78
centrala@normavariant.pl

SLOVAC REPUBLIC

Alba s.r.o.
Jilemnického 8
SK-0360 Martin
Tel.: +421 8424239 748
Fax: +421 8424230 813
alba@alba.sk

SLOVENIA

BMT d.o.o.
Nade Ovcakove ul. 17
SI-1000 Ljubljana
Tel.: +386 1 565 8170
Fax: +386 1 565 8175

NORMA Group is a strategic development partner and global solution provider of Engineered Joining Technologies. Our Distribution Services combine the world's leading brands in standard hose and pipe fastenings with unrivalled applications expertise in areas such as Emission Control, Cooling System, Air Intake & Induction, Ancillary System and Infrastructure.

The NORMA® Product Range

- NORMACLAMP®
= Hose Clamps
- NORMACONNECT®
= Pipe Connections
- NORMAFIX®
= Retaining Products
- NORMAQUICK®
= Quick Connectors
- NORMAFLEX®
= Fluid Systems
- NORMAPLAST®
= Plastic Products

This catalogue supersedes all previous issues. No part of this publication may be reproduced without our prior written consent. In NORMA Group's policy of continual product improvements to meet user needs and technological developments, all models and sets listed in this folder (photographs, specifications, sizes and weights) may be upgraded or discontinued without notice and without any obligation on our part to modify tools or equipment sold previously. The recommendations for use and safety given in this folder do not replace accepted good practice or the safety related legal and regulatory provisions. References to standards implemented at 01/02/2012 are not contractually binding.

NORMA Germany GmbH

Postfach 11 49 · D-63461 Maintal
Edisonstraße 4 · D-63477 Maintal

Tel.: +49 (61 81) 4 03-0

Fax.: +49 (61 81) 4 03-2 10

info@normagroup.com

NORMA® ist ein eingetragenes Warenzeichen der
NORMA Germany GmbH.

*NORMA® is a registered trademark of
NORMA Germany GmbH.*

NORMA Group